



QUICK REFERENCE

SKILL LEVEL	12yrs +
EQUIPMENT	GLUE GUN, MARKER, CRAFT KNIFE
TIME	2 hours

CARD BOARD

CROSSBOW



it really works and **fires** drinking straws

Junk used to make this model... old cardboard box, wire coat hanger, wine bottle cork, 2 x old ball point pens, rubber band, some drinking straws, printed sheet of templates

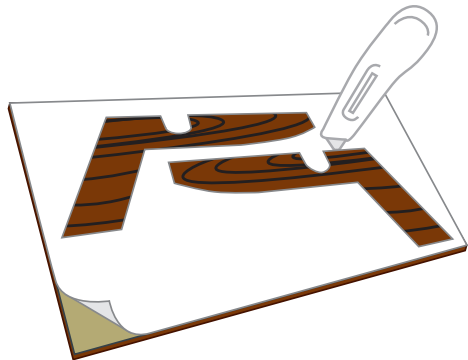

1. PRINT OUT THE TEMPLATES GLUE THE LEFT AND RIGHT OUTSIDES TO A PIECE OF CORRUGATED CARDBOARD AND CAREFULLY CUT OUT

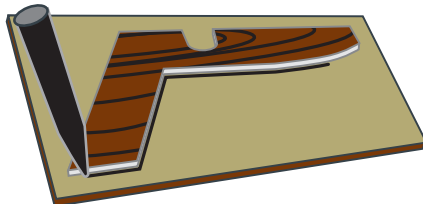

2. USING EITHER OF THE CUTOUTS AS A TEMPLATE, MARK OUT FOUR MORE CROSSBOW SHAPES

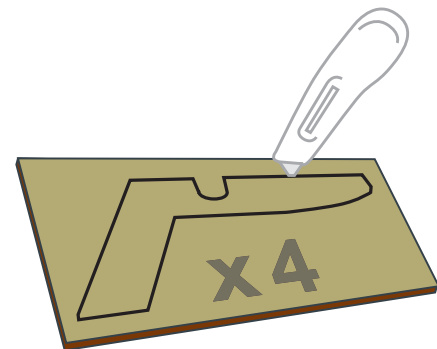

3. CAREFULLY CUT OUT ALL THE TEMPLATES, REMEMBERING TO CUT TO THE INSIDE OF THE MARKED LINE

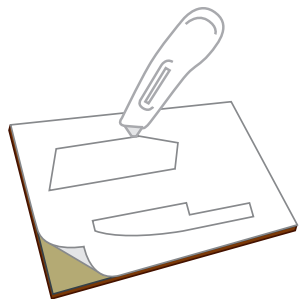

4. GLUE THE INNER PART TEMPLATES TO A PIECE OF CORRUGATED CARDBOARD AND CAREFULLY CUT OUT

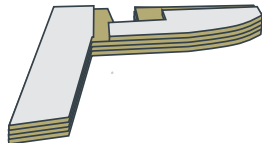

5. LAY THE CROSSBOW BODY TOGETHER, PLACING THE INNER PARTS AS SHOWN AS THE FOURTH LAYER BUT DO NOT GLUE

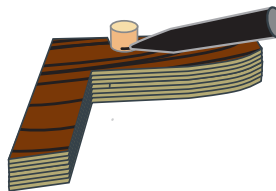

6. PUT THE CORK IN POSITION AND MARK THE CORRECT DEPTH AS THE THICKNESS OF THE CROSSBOW BODY

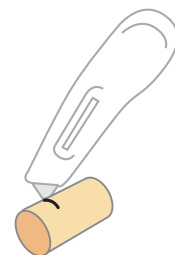

7. CUT CORK TO LENGTH

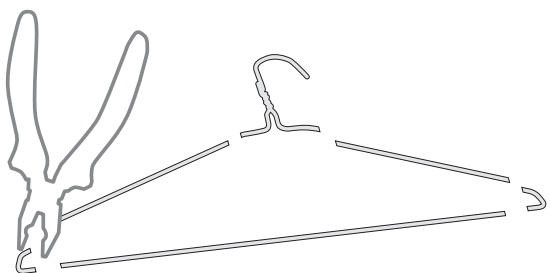

8. CUT WIRE COAT HANGER INTO 3 BIG PIECES

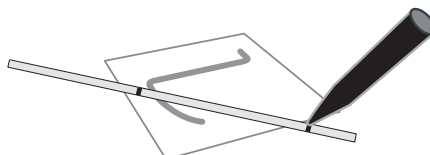

9. MARK BENDS ON ONE OF THE SHORTER PIECES AS PER TEMPLATE

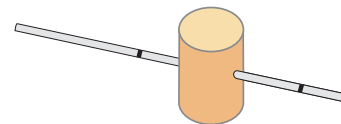

10. POKE THROUGH CORK, STRAIGHT AND IN THE MIDDLE

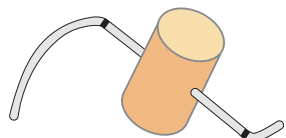

11. BEND AS PER THE MARKS TO THE SHAPE OF THE TEMPLATE, MAKING SURE THAT IT IS ONLY BENT IN ONE PLANE

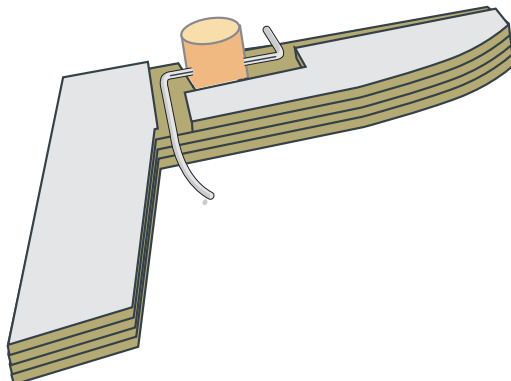

12. NOW ASSEMBLE THE CROSSBOW BODY GLUING EACH SECTION TO THE ONE BELOW, MAKING SURE THEY ALL LINE UP ACCURATELY, IN THE FOLLOWING ORDER:
- i) LEFT HAND OUTSIDE PIECE
 - ii) TWO FULL BODY PIECES
 - iii) INNER PIECES.
 - iv) DROP IN THE TRIGGER ASSEMBLY MAKING SURE NOT TO GET GLUE ON IT
 - v) TWO FULL BODY PIECES
 - vi) FINISH WITH THE RIGHT HAND OUTER SIDE



QUICK REFERENCE	
SKILL LEVEL	12yrs +
EQUIPMENT	GLUE GUN, MARKER, CRAFT KNIFE
TIME	2 hours

CARD BOARD

CROSSBOW

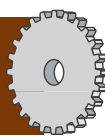

it really works and **fires** drinking straws

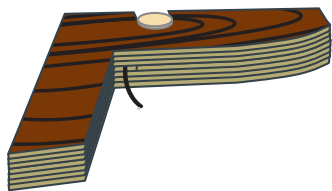

13. ONCE THE MAIN BODY IS ASSEMBLED AND GLUED TOGETHER, THE TRIGGER MECHANISM CAN BE SLIPPED IN AND OUT. FINE TUNE THE BENDS TO MAKE SURE THAT THE MECHANISM IS STRAIGHT AND THAT THE TOP LATCH STICKS UP ABOVE THE BODY OF THE



14. CUT A STRIP OF CORRUGATED CARDBOARD WIDE ENOUGH TO FIT THE WIDTH OF YOUR CROSSBOW AND GLUE TO THE EDGE OF THE BODY FROM THE BACK OF THE LATCH ROUND THE GRIP AND UP TO THE TRIGGER, TAKING GREAT CARE NOT TO GET GLUE ON THE CORK

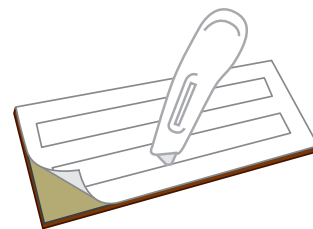

15. TO MAKE THE BOW, PRINT OUT THE TEMPLATES AND STICK TO A PIECE OF CORRUGATED CARDBOARD AND CAREFULLY CUT OUT

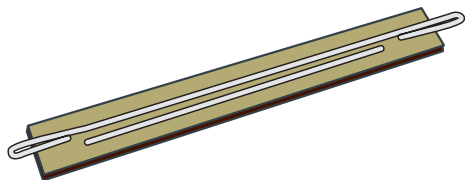

16. TO STRENGTHEN THE BOW, AND PROVIDE A HOOK FOR THE RUBBER-BAND, TAKE THE LONGER OF THE TWO REMAINING CUT PIECES OF COAT HANGER AND BEND OVER AT THE ENDS SO THAT IT IS ABOUT 20mm LONGER THAN THE BOW. LAY THE LONG PIECE AND THE REMAINING SHORT PIECE OF COAT HANGER WIRE ALONG THE LENGTH

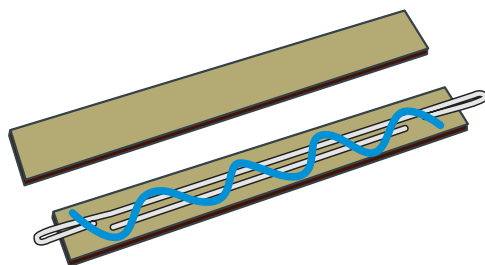

17. APPLY GLUE GUN GLUE GENEROUSLY OVER THE WIRES ONTO THE BOW AND...

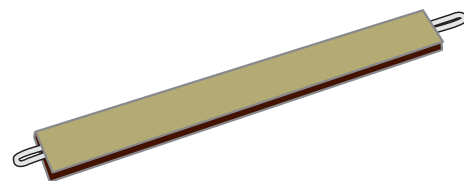

18. ...WHILE HOT PRESS THE OTHER BOW PART DOWN ON TOP, TAKING CARE TO MAKE SURE THE TOP AND BOTTOM ARE ALIGNED, AND TAKING CARE NOT TO BURN YOURSELF ON THE HOT MELT GLUE WHICH SQUEEZES OUT THE SIDE OF THE JOIN.

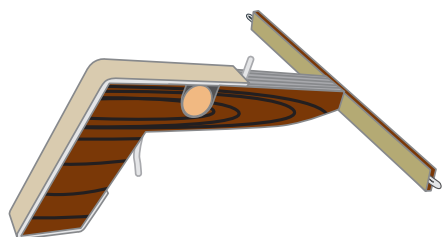

18. GLUE BOW ON TO CROSSBOW BODY, MAKE SURE IT IS SQUARE AND CENTRED AND THAT THE TOP EDGE LINES UP WITH THE TOP EDGE OF THE CROSSBOW

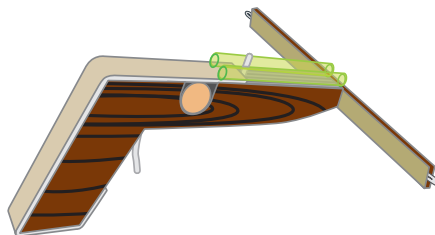

19. TO MAKE THE DART GUIDES GLUE TWO EMPTY BALL POINT PEN BARRELS TO THE TOP OF THE CROSSBOW BODY, MAKING SURE THAT THEY EXTEND BEHIND THE LATCH AND THE LATCH CAN STILL

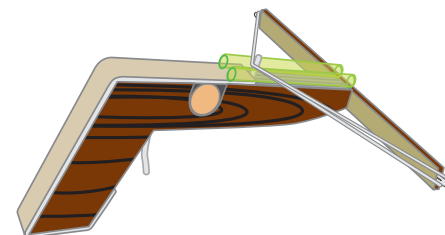

20. FIT THE RUBBER BAND OVER THE BOW HOOKS AND ROUND THE LATCH

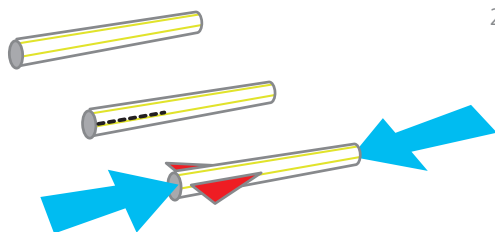

21. TO MAKE THE DART, USE EITHER A ROLLED UP PIECE OF PAPER OR A DRINKING STRAW. CUT TO ABOUT 80mm. CUT FLIGHT FROM PRINTED TEMPLATE AND INSERT INTO SLIT SO THAT FLIGHT TRAILING EDGE IS PAST END OF STRAW. APPLY GLUE GUN GLUE TO EITHER END WITH SLIGHTLY MORE IN TIP

